

Description

The DL3603P3 is a low capacitance TVS array, utilizing leading monolithic silicon technology to provide fast response time and low ESD clamping voltage, making this device an ideal solution for protecting voltage sensitive high-speed data lines. The DL3603P3 complies with the IEC 61000-4-2 (ESD) standard with $\pm 25\text{kV}$ air and $\pm 20\text{kV}$ contact discharge. It is assembled into a 6-pin DFN1616-6 lead-free package. Each device will protect up to four high speed lines. The combination of small size, low capacitance, and high surge capability makes them ideal for use in applications such as USB ports.

Features

- ◆ Low capacitance: 0.4pF typical(I/O to I/O)
- ◆ Ultra low leakage: nA level
- ◆ Low operating voltage: 5V
- ◆ Low clamping voltage
- ◆ Up to 3 data lines and one power line protects
- ◆ Complies with following standards:
 - IEC 61000-4-2 (ESD) immunity test
 - Air discharge: $\pm 25\text{kV}$
 - Contact discharge: $\pm 20\text{kV}$
- ◆ RoHS Compliant

Mechanical Characteristics

- ◆ Package: DFN1616-6
- ◆ Case Material: "Green" Molding Compound.
- ◆ Moisture Sensitivity: Level 3 per J-STD-020
- ◆ Terminal Connections: See Diagram Below
- ◆ Marking Information: See Below

Applications

- ◆ USB 2.0
- ◆ USB OTG

Dimensions and Pin Configuration

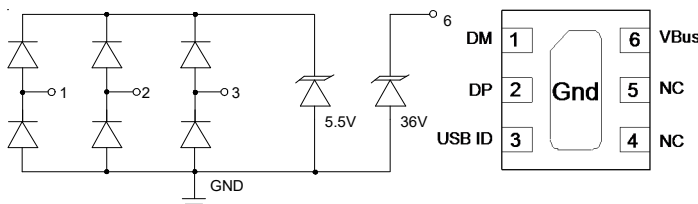

Circuit Diagram

Pin Schematic

Marking Information

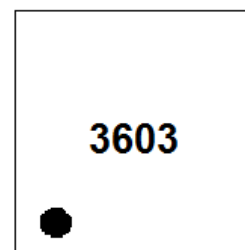

3603 = Device Marking Code

Dot denotes Pin1

Ordering Information

Part Number	Marking	Packaging	Reel Size
DL3603P3	3603	3000/Tape & Reel	7 inch

Absolute Maximum Ratings ($T_A=25^\circ\text{C}$ unless otherwise specified)

Parameter	Symbol	Value	Unit
DP, DM, USB ID (Pins 1, 2, 3)			
Peak Pulse Power (8/20 μs)	Ppk	100	W
Peak Pulse Current (8/20 μs)	IPP	5	A
ESD per IEC 61000-4-2 (Air)	VESD	± 25	kV
ESD per IEC 61000-4-2 (Contact)		± 20	
Operating Temperature Range	TJ	-55 to +125	$^\circ\text{C}$
Storage Temperature Range	Tstg	-55 to +150	$^\circ\text{C}$
VBus (Pin 6)			
Peak Pulse Power (8/20 μs)	Ppk	300	W
Peak Pulse Current (8/20 μs)	IPP	4	A
ESD per IEC 61000-4-2 (Air)	VESD	± 25	kV
Operating Temperature Range	TJ	-55 to +125	$^\circ\text{C}$
Storage Temperature Range	Tstg	-55 to +150	$^\circ\text{C}$

Electrical Characteristics ($T_A=25^\circ\text{C}$ unless otherwise specified)

Parameter	Symbol	Min	Typ	Max	Unit	Test Condition
DP, DM, USB ID TVS						
Reverse Working Voltage	VRWM			5.5	V	Any I/O to ground
Breakdown Voltage	VBR	6.5			V	$I_T = 1\text{mA}$, any I/O to ground
Reverse Leakage Current	I_R			0.5	μA	VRWM = 5.5V, any I/O to ground
Clamping Voltage	VC			10	V	IPP = 1A (8 x 20 μs pulse), any I/O pin to ground
Clamping Voltage	VC			20	V	IPP = 5A (8 x 20 μs pulse), any I/O pin to ground
Junction Capacitance	CJ			0.5	pF	VR = 0V, f = 1MHz, between I/O pins
Junction Capacitance	CJ			0.8	pF	VR = 0V, f = 1MHz, any I/O pin to ground

Note: I/O Pins are 1, 2, 3

Parameter	Symbol	Min	Typ	Max	Unit	Test Condition
VBus TVS						
Reverse Working Voltage	VRWM			36	V	Pin 6 to ground
Breakdown Voltage	VBR	38		45	V	IT = 1mA, pin 6 to ground
Reverse Leakage Current	IR			0.2	μA	VRWM = 36V, pin 6 to ground
Clamping Voltage	VC			50	V	I _{PP} = 1A (8 x 20μs pulse), pin 6 to ground
Clamping Voltage	VC			75	V	I _{PP} = 4A (8 x 20μs pulse), pin 6 to ground
Junction Capacitance	CJ			100	pF	VR = 0V, f = 1MHz, pin 6 to ground

Typical Performance Characteristics (TA=25°C unless otherwise Specified)

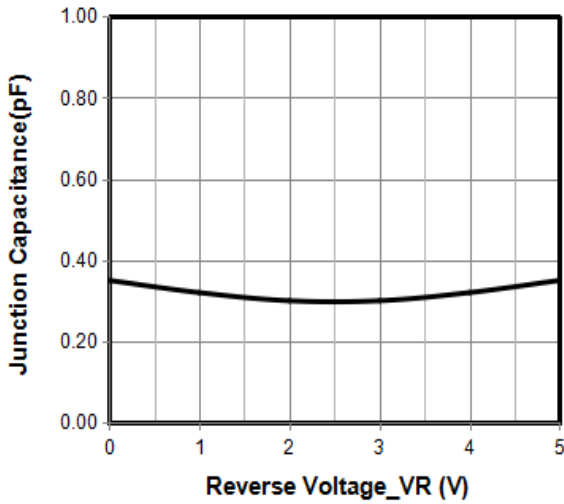

Junction Capacitance vs. Reverse Voltage

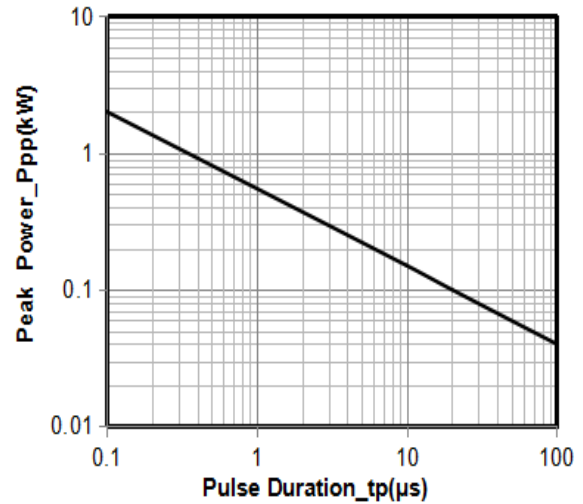

Peak Pulse Power vs. Pulse Time

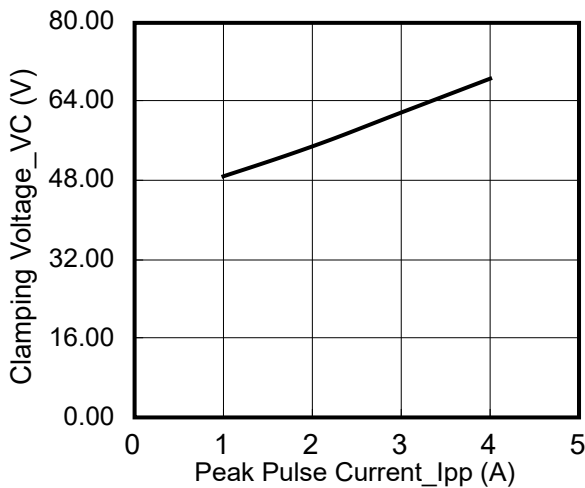

Clamping Voltage vs. Peak Pulse Current

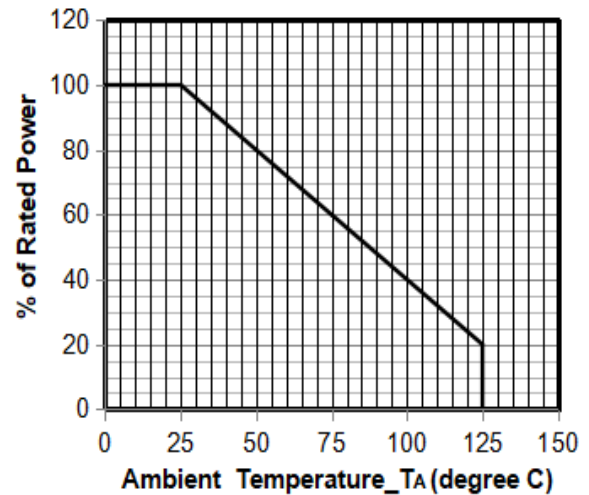

Power Derating Curve

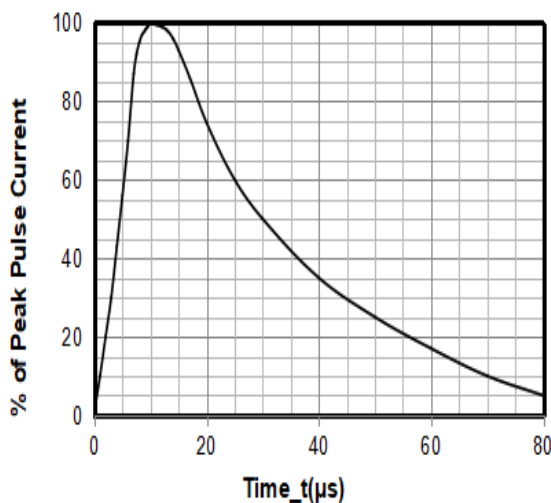

8 X 20μs Pulse Waveform

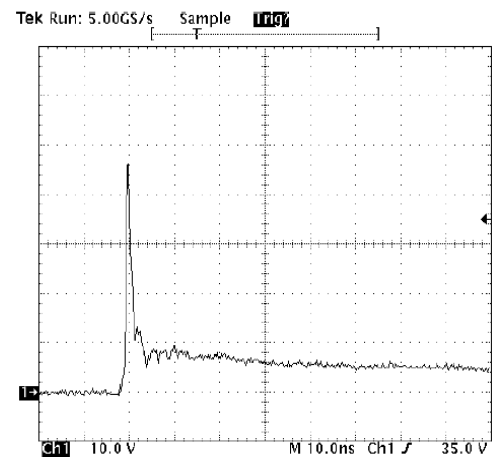

Note: Data is taken with a 10x attenuator

ESD Clamping Voltage

8 kV Contact per IEC61000-4-2

DL3603P3 on USB Port Application

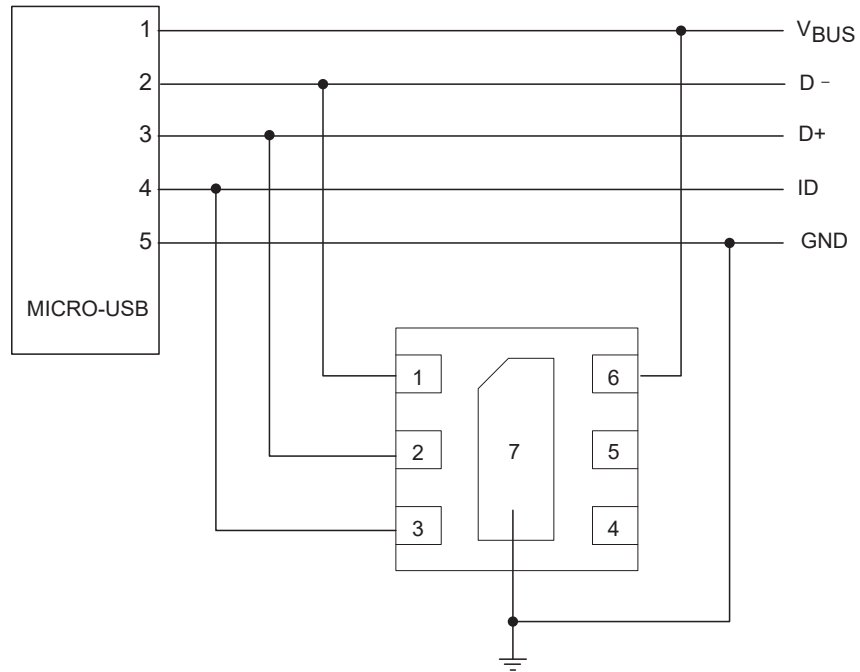

DFN1616-6 Package Outline Drawing

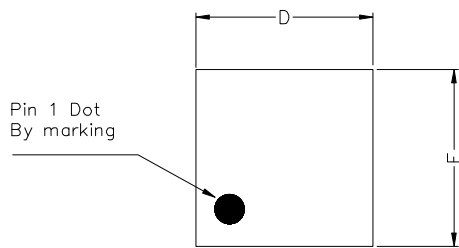

TOP VIEW

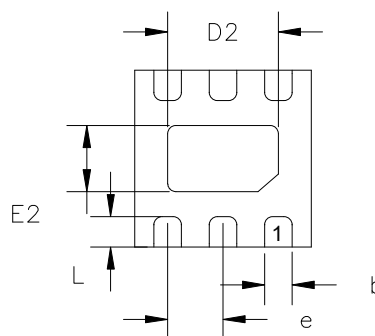

BOTTOM VIEW

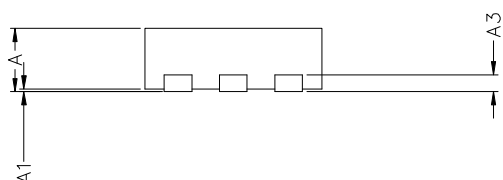

SIDE VIEW

COMMON DIMENSIONS(MM)			
PKG.	UT: ULTRA THIN		
REF.	MIN.	NOM.	MAX.
A	0.50	0.55	0.60
A1	0.00	—	0.05
A3	0.15 REF.		
D	1.55	1.60	1.65
E	1.55	1.60	1.65
D2	0.90	1.00	1.05
E2	0.50	0.60	0.65
L	0.20	0.25	0.30
b	0.20	0.25	0.30
e	0.50 BSC		

Suggested Land Pattern

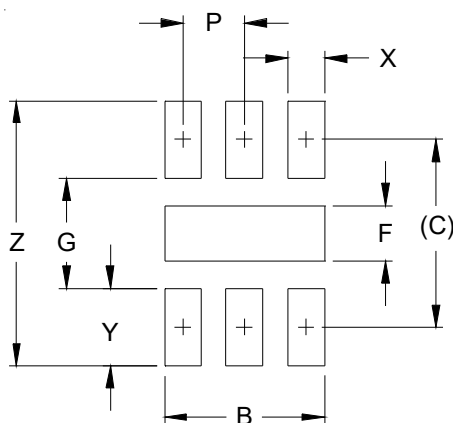

DIMENSIONS		
DIM	INCHES	MILLIMETERS
B	.051	1.30
C	.060	1.52
P	.020	0.50
F	.018	0.45
G	.035	0.89
X	.012	0.30
Y	.025	0.63
Z	.085	2.15

Contact Information

Changzhou D-first Electronics CO.,Ltd.

www.first-electronic.com

Email: xhf@first-electronic.cn

Phone: +86 (0519) 8817 1671